

# MODEL 32P HORIZONTAL BEAM

The 32P was designed with crisp, clear telecentric optics and a precision solid cast iron stage to be an instrument capable of handling almost any measurement/inspection requirement. This welded steel fabrication assures years of accurate, trouble free service.

## FEATURES:

- 32" (800mm) Vertical screen for optimum viewing
- Erect and reversed profile image
- High resolution ground glass screen with calibration reticle, 90 degree cross lines and chart clips
- Machined chart ring with vernier protractor, 1 minute graduation facilitates optimal alignment
- Coated telecentric parfocal optics
- 3 position rotary lens & condenser turret
- Quartz halogen profile light source 24V, 150W
- Bright 500W fiber optic surface illumination
- Linear Scale Resolution 0.00025mm/.00001"
- Solid cast iron nickel plated stage
  - Triple universal dovetails
  - 36" x 8" Overall size
  - Solid crossed roller stage bearings
  - 500 lbs capacity
  - 18" X Axis motorized travel
  - 10" Y Axis motorized travel
  - ±15 Degree true parfocal helix stage adjustment, with 5 minute vernier
  - Joystick control, computerized microstep motor controller with X and Y axes & focus
- Integrated hood
- NIST traceable calibration certificate
- 2 Year limited warranty



## OPTIONAL FEATURES:

- Internal edge detection
- Output for electronic rotary screen protractor (Q axis) with selectable 1 minute or 1/100 of a degree resolution
- Choice of readout options see pages 11-13
- CNC computer controlled readout systems
- 24" extended stage travel on "X" axis
- Harsh Environment package
- Extended hood & curtains

## DIMENSIONS

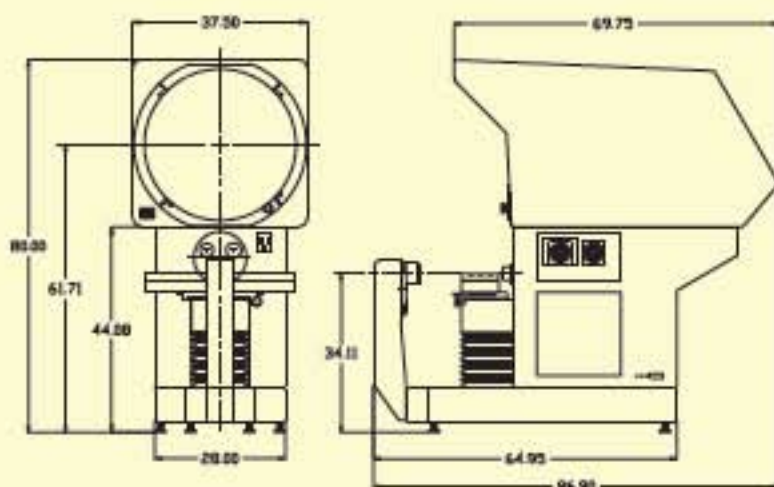

Technical Specification	
Illumination	Profile: Built-in 24V/150W direct collimated halogen Surface: Two built-in 24V/250W via fiber optics
Screen Size	32" (800mm) Ground glass with cross-lines
Stage	Cast iron, nickel plated, 36" x 8", twin dovetail
Stage Travel	X = 18" (460mm), Motorized Y = 10" (250mm), Motorized Focus = 3" (75mm), Motorized
Stage Accuracy	Within +/- 0.004mm +[(L/20).001]
Linear Scale Resolution	Standard: 0.00025mm/.000010"
Repeatability of Scales	+/- 1 Scale count (0.0005mm/.00002")
Coated Telecentric Lenses	5x, 10x, 20x, 25x, 31.25x, 50x, 62.5x, 100x
Optical Accuracy	Within +/- .10% Profile, +/- .15% Surface
Power Requirements	120V or 240V AC, 50/60 Hz, 10 Amp
Weight	3950 lbs/1792 kg