



Instruments for Surface Texture Measurement



1.

A REVOLUTIONARY CONCEPT

The need for miniaturization and increased machining accuracy has accelerated the evolution of materials technology from the micro to the nano scale. More and more, traditional scanning, 2D and contact metrological techniques do not have the capacity to properly characterize these surfaces. A new method of measurement is needed that has the required resolution and speed along with being non-destructive and truly three dimensional. The Trimos® TR Scan with DHM® technology is the solution.





Interchangeable Measuring Heads

The unique system of interchangeable measuring heads confers a high degree of adaptability to every application. Changing a head is quick and automatically recognized by the system. Several technologies are available for complete application coverage.



A. Automated Z-Axis and Modular Measuring Table

Motorized X, Y, Z axes allow for precise and automated measurements. It includes the ability to image large areas by the use of stitching and the convenience of automatic working distance detection. The modularity of the X or XY sample stage offers a high degree of customization based on application.

B. No special skills needed

Trimos Nanoware allows for measurements to be taken automatically, using predefined parameters, or manually with only the input of the measurement size. Reports can be generated with one touch through the use of predefined parameters and analysis templates, eliminating the need for specialized training and measurement errors.

Highly Flexible System

The Trimos TR Scan is a flexible and universal surface texture measurement system focusing on Digital Holographic Imaging Technology. No other tool can compare to its combined speed, resolution, ease of use and flexibility. Its automated and modular design allow for a high degree of customization based on application's needs and increased functionality with integrated stitching and profilometer compatibility.

Due to its simplicity, the TR Scan can be operated by workshop personnel and reliable results secured with minimum training.

All measured surfaces can be treated according to current international standards such as ISO, DIN, JIS, ASME, CNOMO etc., as well as the upcoming ISO 25178 3D standard.

The TR Scan is completely designed and manufactured in Switzerland according to the highest quality standards. Robustness reliability and longevity is our tradition. Trimos instruments have been used in workshops and labs for over 30 years.

2.

QUICK AND EFFICIENT MEASUREMENTS

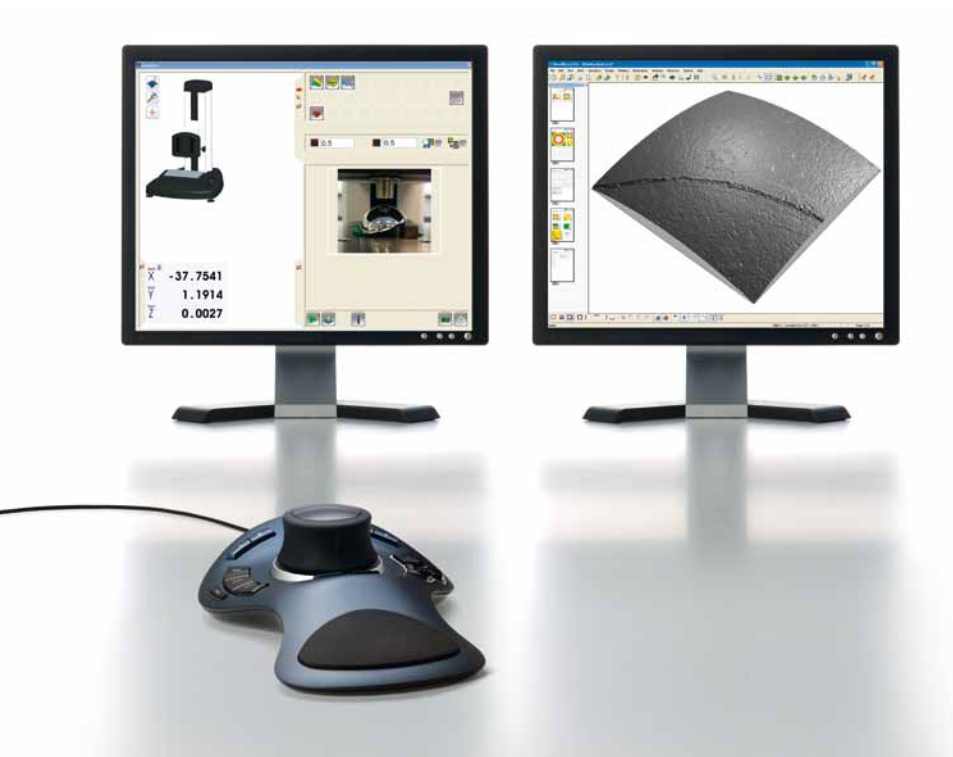

Intuitive Positioning

Positioning in X,Y,Z is performed either automatically by predefined parameters or via the use of an intuitive joystick aided by an integrated positioning laser and a camera (optional).

Instant Measurement

Once positioned, measurements are taken automatically with one click or via the use of a manual size parameter in a few seconds.

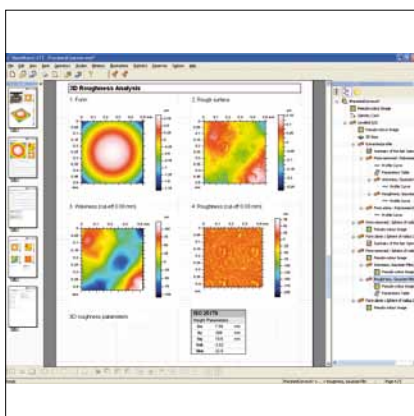

Powerful Analysis

Analysis can be performed automatically by the use of a template or the user can have direct access to the raw data. The incorporated analysis software is powered by Mountains®, the most powerful and recognized 2D/3D surface analysis software available.

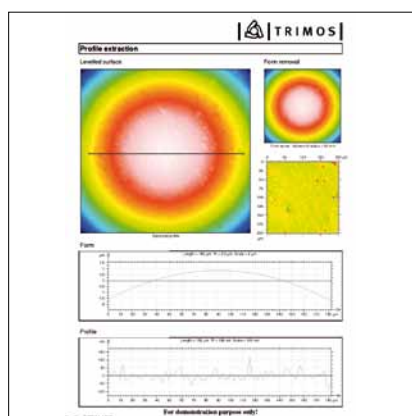

Professional Reporting

Reports are automatically generated during analysis. Any report can be used as a template later.

3.

THE DHM TECHNOLOGY

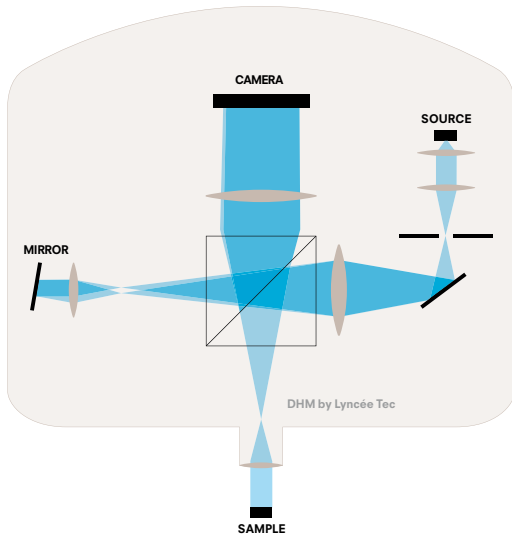

DHM® (Digital Holographic Microscopy) is a non-contact surface measurement technology originally developed for the biotech and medical industry. DHM generates a high-resolution 3D digital image of a sample using the principle of holography. A hologram generated by combining a coherent reference wave with the wave received from a sample is recorded by a CCD camera and transmitted to a computer for numerical reconstruction.

A single hologram is acquired in a few microseconds, making the whole system insensitive to vibrations. Software procedures allow computation of the complete wavefront emanating from an object and provides:

- Intensity images providing the same contrast as with classical optical microscopy
- Phase images providing quantitative data, defined at a sub-wavelength scale, used for accurate and stable 3D measurements.

The phase image reveals the surface topography with a sub-nanometric vertical resolution. This digital approach to holography allows the application of computer-based procedures at a level never reached in optical microscopy so far. In particular the DHM principle features software compensation of optical aberrations, digital image focusing and numerical compensation for sample tilt and environmental disturbances, making DHM instruments robust and easy to use for routine inspections at the nanometer and micrometer scale. DHM is used exclusively by Trimos for surface texture measurement. This technology has numerous advantages compared to other contact and non-contact measurement technologies: in particular extremely fast measurements, high resolution, simple working process no moving parts and no requirement for special environmental conditions.

- Acquisition in a few microseconds
- Vibration insensitive
- High image quality
- Subnanometric resolution
- No moving parts
- No requirement for special environmental conditions

DHM is a recognized surface texture measurement method according to the standard ISO 25178-6.

4.

APPLICATIONS VERSATILITY

The TR Scan provides rapid, reliable and accurate surface texture characterization for a large application range and materials such as steel, aluminum, brass, titanium, silicon, gold, ceramics, glass etc. The system can be tailored to fit the requirements of many industries :

- Automotive
 - Aircraft
 - Machine Tool
 - Watch
 - Printing
 - Railway
 - Bearing
 - Medical
- Materials
 - Optics
 - Forensic
 - Photovoltaic
 - MEMS
 - Semiconductor
 - Electronic



Steel Surface spinning measurement on a printing roll (DHM S2)



Titanium Texture analysis of a chemically polished surface (DHM S2)

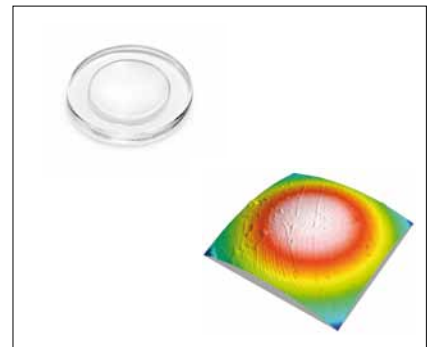

Glass Roughness inspection of micro lenses (DHM S2)

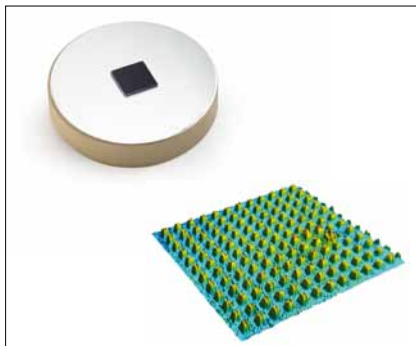

Silicon Analysis of a silicon microstructure (DHM S2)

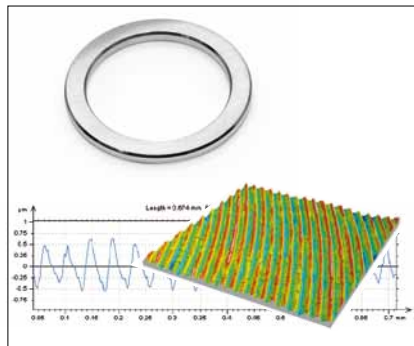

Aluminium Verification of a ring type joint gasket for the aircraft industry (DHM S2)

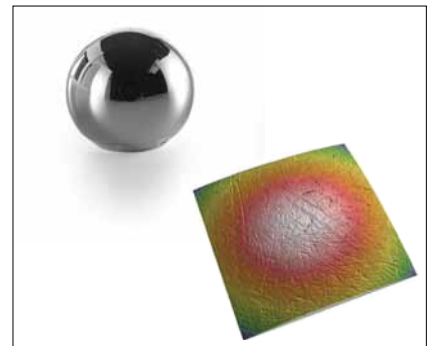

Cobalt-chromium Quality control of a polished prosthesis surface (DHM-S2)

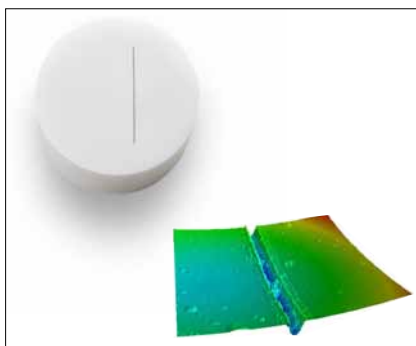

Ceramics Depth measurement of a laser engraving (CCM-P1)

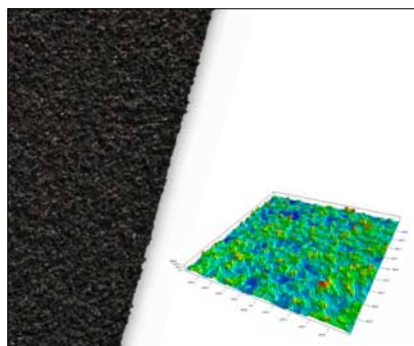

Abrasive Surface texture analysis of an industrial abrasive material (CCM P1)

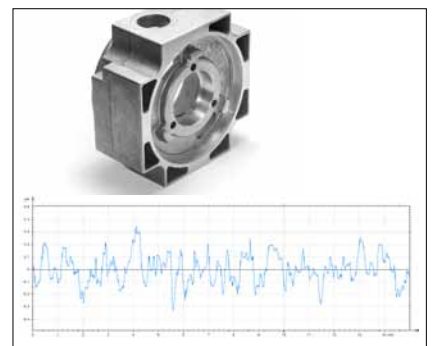

Stylus tip Classical 2D internal roughness measurement (DIA P1)

5.

TECHNICAL SPECIFICATIONS

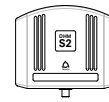
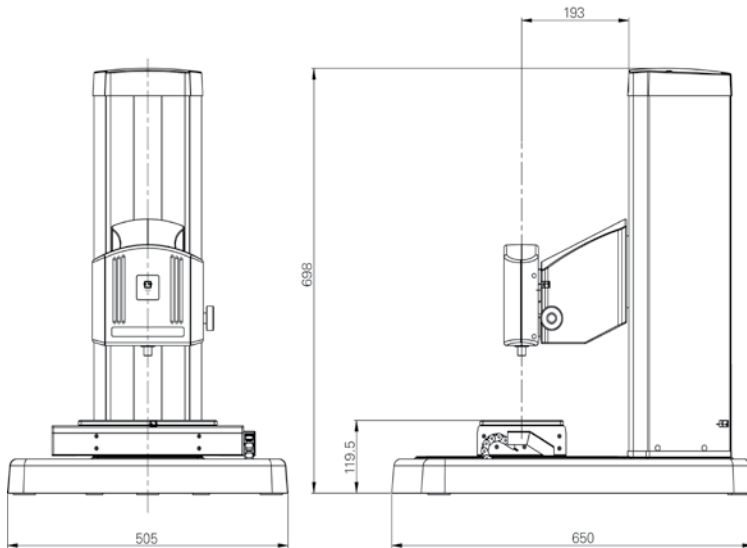

DHM S2

DHM Technology

- Smooth surfaces, grinded or polished
- High precision and measurement speed

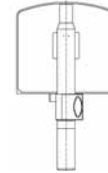

CCM P1

Chromatic Confocal Technology

- Rough surfaces, microforms
- Light-diffusing materials, plastics, biomaterials

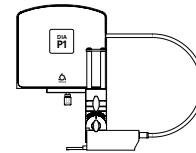

DIA P1

Diamond Stylus Tip Technology

- Classical roughness measurement
- Internal measurements

TR-SCAN

● MEASURING HEADS

		DHM S2	CCM P1	DIA P1
Technology		DHM	Chromatic Confocal	Stylus tip
Vertical resolution (Z)	nm	0.1	5 .. 35 ²⁾	10
Lateral resolution (XY)	µm	0.6	1.1 .. 4.0 ²⁾	1
Typical max. measuring range Ra ¹⁾	µm	1	20 .. 200 ²⁾	20
Typical max. measuring range Rz ¹⁾	µm	5	300 .. 1100 ²⁾	200
Max. permissible errors Ra	%	1%	1% .. 5% ²⁾	5%
Repeatability (Ra, 1σ)	nm	< 0.1	<5 .. 25 ²⁾	9
Sample reflectivity	%	< 1% - 100%	1% - 100%	-
Field of view	mm	0.25 x 0.25	-	-

1) Values may differ depending on the surface texture

2) Objective dependent

● INSTRUMENTS

TR Scan		100	200	300
Horizontal measuring range X	mm	-	100	100
Horizontal measuring range Y	mm	-	-	100
Vertical measuring range Z	mm		240	
Meas. System resolution XYZ	µm		0.1	
Positioning accuracy XYZ	µm		1	
Max weight of the part	kg		20	



Instruments for Surface Measurement

TR PROFILE

Compact instrument for the measurement of roughness profiles (2D)
Stylus with and without skid



TR PROFILE DH-7

Portable workshop instrument for the measurement of roughness profiles (2D)
Stylus with and without skid



TR SCAN

CNC instrument for the measurement of roughness profiles (2D) and surfaces (3D)
with and without contact

TRIMOS SA

Av. de Longemalle 5
CH - 1020 Renens
T. + 41 21 633 01 01
F. + 41 21 633 01 02
www.trimos.ch

