

# XT Holematic Pistol Grip

- Large easy-to-read swivel display
- Self centering heads
- RS-232C output
- Two preset memories
- Fixed anvils
- Resolution: .00005" / .001mm
- Range .080—12" (6—200mm)
- Tungsten carbide measuring faces on all 3-point heads from .5" (12.5mm) and up.
- Setting rings included in all sets
- Includes UKAS certificates for all pistol grips and rings.

Fowler/Bowers XT Holematic Pistol Grip range of bore gages offer extended travel with fixed anvils. The pistol grip handle incorporates a constant measuring pressure to eliminate operator "feel."

*Special anvils are available for threads, splines, slots, etc.*



## Electronic Holematic Pistol Grip XT - Individual Gages

Sizes over .500" (12.5mm) feature blind bore capability

Order Number	Range	Accuracy	Depth
54-566-701	.080"—.100" (2—2.5mm)	.00015" (0.004mm)	.350" (9mm)
54-566-702	.100"—.120" (2.5—3mm)	.00015" (0.004mm)	.350" (9mm)
54-566-703	.120"—.160" (3—4mm)	.00015" (0.004mm)	.470" (12mm)
54-566-704	.160"—.200" (4—5mm)	.00015" (0.004mm)	.700" (18mm)
54-566-705	.200"—.250" (5—6mm)	.00015" (0.004mm)	.700" (18mm)
54-566-706	.250"—.312" (6—8mm)	.00015" (0.004mm)	2.28" (58mm)
54-566-708	.312"—.375" (8—10mm)	.00015" (0.004mm)	2.28" (58mm)
54-566-710	.375"—.500" (10—12.5mm)	.00015" (0.004mm)	2.28" (58mm)
54-566-712	.500"—.625" (12.5—16mm)	.00015" (0.004mm)	2.44" (62mm)
54-566-716	.625"—.750" (16—20mm)	.00015" (0.004mm)	2.44" (62mm)
54-566-720	.750"—1" (20—25mm)	.00015" (0.004mm)	2.62" (66mm)
54-566-725	1—1.375" (25—35mm)	.00015" (0.004mm)	2.62" (66mm)
54-566-735	1.375"—2" (35—50mm)	.00015" (0.004mm)	3.15" (80mm)
54-566-740	2—2.625" (50—65mm)	.0002" (0.005mm)	3.15" (80mm)
54-566-745	2.625"—3.250" (65—80mm)	.0002" (0.005mm)	3.15" (80mm)
54-566-750	3.250"—4" (80—100mm)	.0002" (0.005mm)	3.35" (85mm)
54-566-800	4—5" (100—125mm)	.00025" (0.006mm)	3.94" (100mm)
54-566-825	5—6" (125—150mm)	.00025" (0.006mm)	3.94" (100mm)
54-566-850	6—7" (150—175mm)	.0003" (0.007mm)	3.94" (100mm)
54-566-875	7—8" (175—200mm)	.0003" (0.007mm)	3.94" (100mm)
54-566-876	8—9" (200—225mm)	.0003" (0.008mm)	3.94" (100mm)
54-566-777	9—10" (225—250mm)	.0003" (0.008mm)	4.05" (103mm)
54-566-878	10—11" (250—275mm)	.00035" (0.009mm)	4.05" (103mm)
54-566-879	11—12" (275—300mm)	.00035" (0.009mm)	4.05" (103mm)

**For a complete listing of replacement heads, pistol grip handles/readouts and rings refer to our main catalog or visit us online at [www.fvowler.com](http://www.fvowler.com)**

# XT Holematic Pistol Grip Sets



## Large Capacity Sets

Order Number	Range	Includes
54-566-009	.080"—.250" (2—6mm)	5 heads, 1 handle, 3 rings
54-566-010	.250"—.375" (6—10mm)	2 heads, 1 handle, 1 ring
54-566-020	.375"—.750" (10—20mm)	3 heads, 1 handle, 2 rings
54-566-050	.750"—2" (20—50mm)	3 heads, 1 handle, 2 rings
54-566-100	2—4" (50—100mm)	3 heads, 1 handle, 2 rings
54-566-105	4—6" (100—150mm)	2 heads, 1 handle, 1 ring
54-566-110	6—8" (150—200mm)	2 heads, 1 handle, 1 ring
54-566-200	4—8" (100—200mm)	4 heads, 1 handle, 2 rings
54-566-210	.750"—4" (10—100mm)	6 heads, 1 handle, 4 rings
54-566-620	.250"—.750" (6—20mm)	5 heads, 1 handle, 3 rings

## Accessories



### Electronic Holemike XT Extensions

Order Number	Length	Fits Heads
54-336-301	2.5" (63mm)	.250"—.375" (6—10mm)
54-336-302	3" (76mm)	.375"—.500" (10—12.5mm)
54-336-303	4" (100mm)	.500"—.750" (12.5—20mm)
54-336-304	6" (150mm)	.750"—2" (20—50mm)
54-336-305	6" (150mm)	2"—8" (50—200mm)
54-336-306	20" (500mm)	.750" and higher
54-336-307	40" (1000mm)	1.375" and higher

### Holematic XT Pistol Grip Only

Order Number	Range
54-556-350	.080"—1/4" / 2—6mm
54-556-375	1/4"—3/4" / 6—20mm
54-556-400	3/4"—4" / 20—100mm
54-556-480	4"—12" / 100—300mm

### Replacement Heads

Order Number	Size
54-342-006	.080"—.100" (2-2.5mm)
54-342-007	.100"—.120" (2.5-3mm)
54-342-008	.120"—.160" (3-4mm)
54-342-009	.160"—.200" (4-5mm)
54-342-010	.200"—.250" (5-6mm)
54-342-011	1/4"—5/16" (6-8mm)
54-342-012	5/16"—3/8" (8-10mm)
54-342-013	3/8"—1/2" (10-12.5mm)
54-342-014	1/2"—5/8" (12.5-16mm)
54-342-015	5/8"—3/4" (16-20mm)
54-342-016	3/4"—1" (20-25mm)
54-342-017	1—1-3/8" (25-35mm)

### Replacement Heads

Order Number	Size
54-342-018	1-3/8"—2" (35-50mm)
54-342-019	2—2-5/8" (50-65mm)
54-342-020	2-5/8"—3-1/4" (65-80mm)
54-342-021	3-1/4"—4" (80-100mm)
54-342-022	4—5" (100-125mm)
54-342-023	5—6" (125-150mm)
54-342-024	6—7" (150-175mm)
54-342-025	7—8" (175-200mm)
54-342-026	8—9" (200-225mm)
54-342-027	9—10" (225-250mm)
54-342-028	10—11" (250-275mm)
54-342-029	11—12" (275-300mm)

### Electronic Holemike XT Setting Rings

Order Number	Size
54-332-004	.100"
54-332-005	.160"
54-332-006	.200"
54-332-007	.312"
54-332-008	.500"
54-332-009	.750"
54-332-010	1.375"
54-332-012	2.625"
54-332-013	3.250"
54-332-014	5"
54-332-015	7"
54-332-016	9"
54-332-017	11"

For a complete listing of replacement heads, pistol grip handles/readouts and rings refer to our main catalog or visit us online at [www.fvfowler.com](http://www.fvfowler.com)

# Bowers Special Applications

## 2 Point Special Measuring Heads

### Groove Measuring Heads

- Available as 2 point head.
- Various anvil forms available.
- Diameters from 1/4-12"/6-300mm.
- XT extended range for tight entry size vs. groove size.

Application View

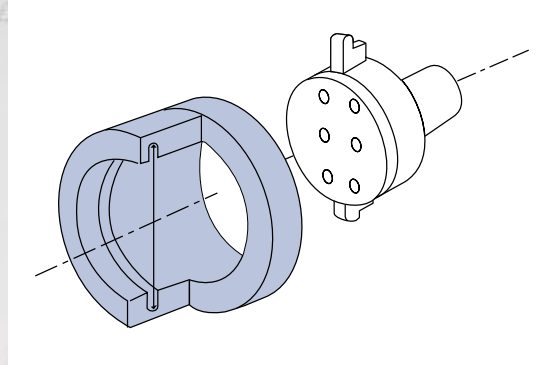

Plan View

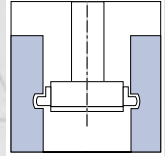

Sample Profile

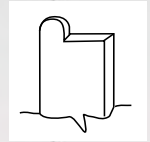

### Thread Measuring Heads

- Available as 2 or 3 point head.
- Any thread form can be made: Ansi, ISO, Whitworth, ACME, JIS, Buttress and Pipe.
- Various anvil forms available.
- Diameters from M4-300mm and 8 UN-12" diameter.

Application View

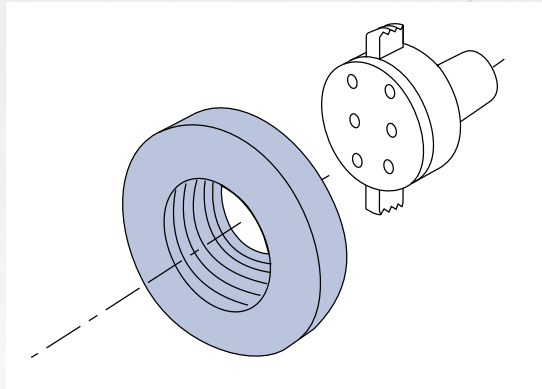

Plan View

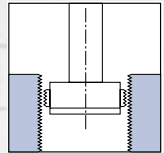

Sample Profile

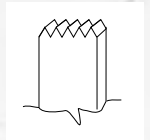

### Special Length - Small Diameter

- Can be supplied in diameters from 2 - 6mm.
- Not available in 3 point.
- Depth dependent on diameter.
- Split cylinder or split ball form.
- Spherical contacts available.
- Excellent for small - deep bore applications.

Application View

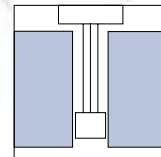
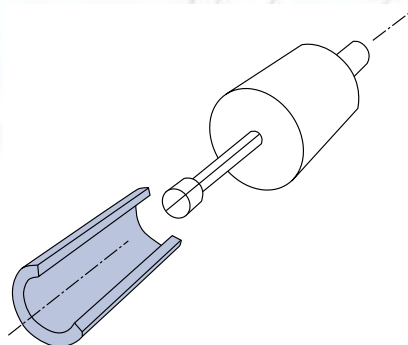

Plan View

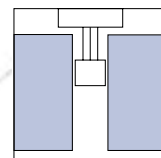

Sample Profile

