

Z_Cal 600 Electronic Height Gage

Fowler/Trimos Z_Cal 600 Height Gage with 24" range. The Z_Cal 600 offers Sylvac's patented measuring system in a stylish easy to use height gage.

**Motorized movement • Low measuring force
Full numeric keypad • Air-bearing base**

Special Features:

- Swiss engineering and construction.
- One hand operation
- Measures heights, internal and external diameters and centerlines.
- Measures centerline location and center distances with dual references.
- Min/Max/Delta modes.
- Optical indicators for tolerances.
- Programmable measuring sequence.
- Includes x charts, histograms and statistics.
- Extremely light measuring pressure (variable)
- Large selection of optional probes with diameters of 1mm and 2mm for miniature parts.
- Built-in pump provides air cushion to reduce wear and fatigue.
- Includes setting gage.

Specifications

Measuring range	0—24"(600mm)
Resolution	.0005"/.00005"(.01/.001mm)
Accuracy	.00024"(6µm)
Repeatability	.00008"/2µm(±2S)
Operational speed	8" (.2mm)/sec
Measuring force	1 oz. (0.3N) adjustable
Operational time	10 hours
Overall height	37"(940mm)
Weight	26.4 lb. (12 kg)
Data output	RS-232 (Bidirectional)



Fowler/Trimos

Order Number

Description

54-930-600-1	24"/600mm Z_Cal 600
54-930-621	Standard 4mm holder
54-930-622	Long 4mm holder
54-930-623	Long 8mm holder
54-930-624	Standard 8mm holder (included with 54-930-600)
54-930-625	Short 8mm holder
54-930-601	Standard 5mm probe (included with 54-930-600)
54-930-602	Long 5mm probe
54-930-603	Depth holder
54-930-604	10mm probe
54-930-215	15 pc. Large deluxe probe set
54-930-217	5 pc. Standard probe set
54-930-202	Z_Cal 600 setting master

Z_Cal 600 Electronic Height Gage

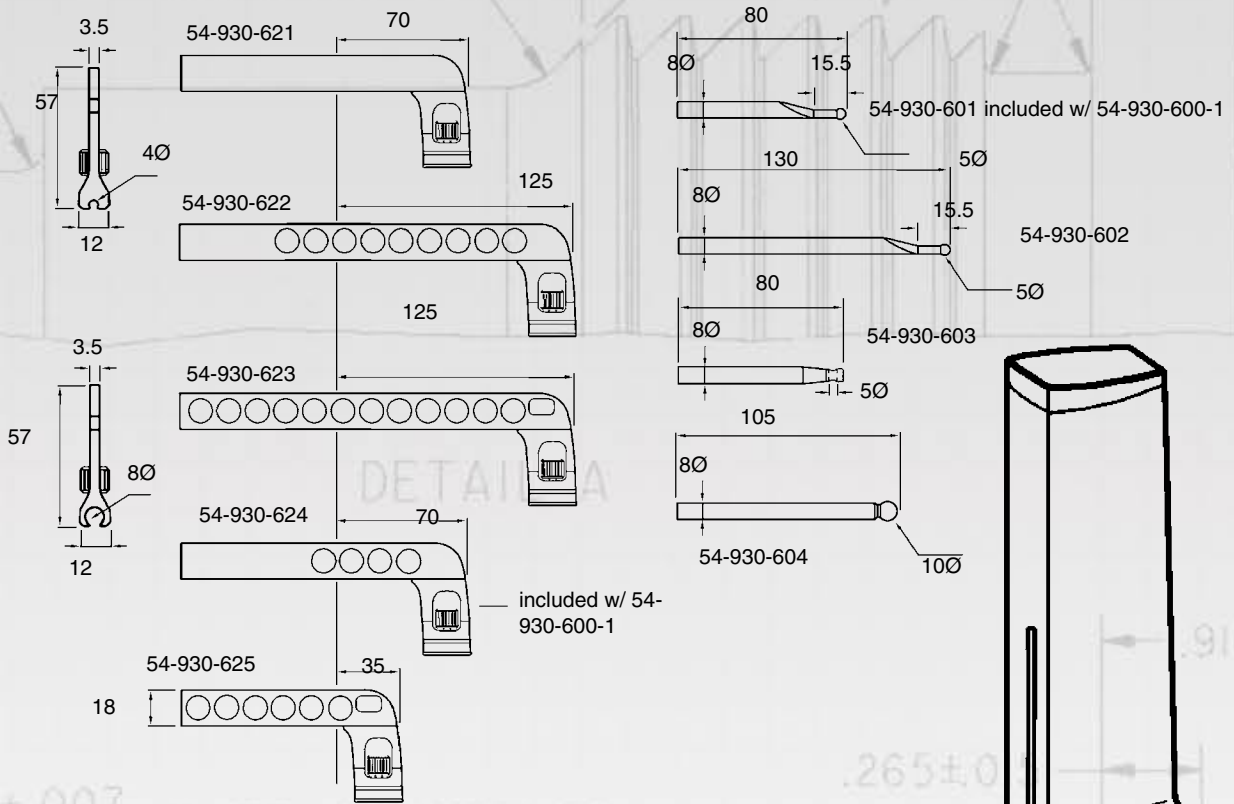

All dimensions are in/mm

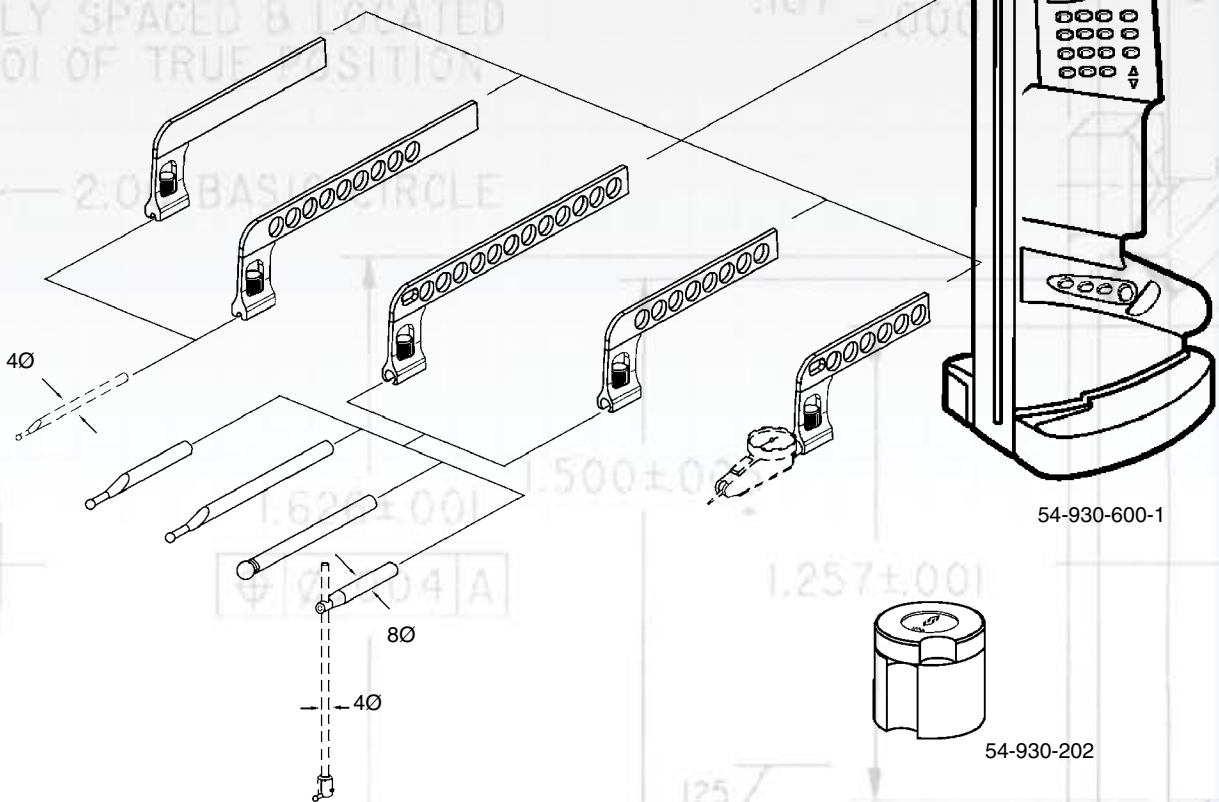

Fowler/Trimos